



**GRIP Head office (Jinsung Eurotec co., ltd.)**

#817 Daerung technotown 12nd Gasandigital 2 ro 14 Geumcheon-gu Seoul Republic of korea.

**GRIP Factory**

#b101-201 397 Seckcheon-ro Buchun-si Gyeonggi-do Republic of Korea

Tel.+82 32 624 0907~8

Fax.+82 32 624 0909

[gripperfect@gmail.com](mailto:gripperfect@gmail.com)

[www.gripkorea.com](http://www.gripkorea.com)



# **HYDRO-PRESET**

Radial Length Adjustment for micron precise positioning.



# HYDRO-PRESET

## Standard Run-Out 3xd 3Micron.

Standard run-out 3  $\mu\text{m}$ .  
ID25/ ID32 run-out 5  $\mu\text{m}$ .

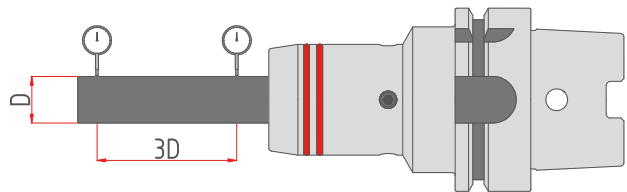

## Micron precise radial length adjustment (10mm) of the tools.

10mm up and down

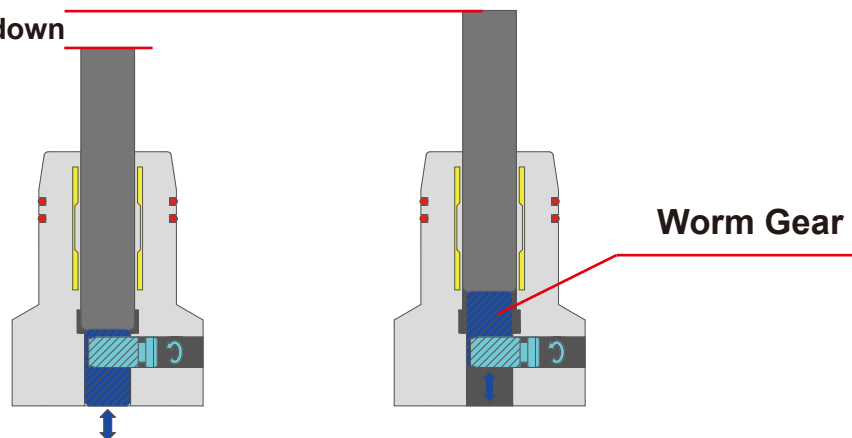

## Reamer, Tap, Drill, Ball end mill, End mill, PCD tool, etc. Many kinds of work possible.

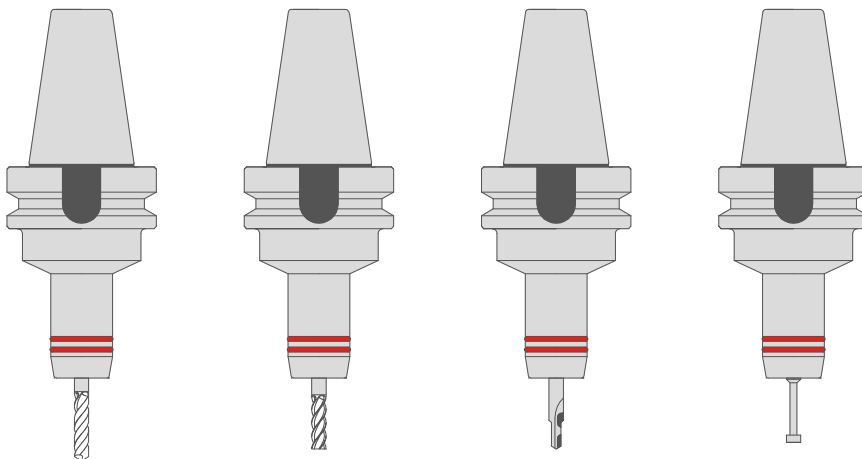



**≡ Suitable for multi-axis spindle machine tool setting.**



**≡ Dimensions(mm)**

HSK-A63		D1	D2	D3	D4	L1	L2	L3	L4	Clamping wrench	Radial Adjustment (wrench)	Kg.
HSK-A63/GPS6/80	●	6	23	26	50	80	37.5	27.5	33	TR-4.0	T-2.0	1.2
HSK-A63/GPS8/80	●	8	25	28	50	80	37.5	27.5	33	TR-4.0	T-2.0	1.2
HSK-A63/GPS10/85	●	10	27	30	50	85	42.5	32.5	38	TR-4.0	T-2.0	1.3
HSK-A63/GPS12/90	●	12	29	32	50	90	47.5	37.5	40	TR-4.0	T-2.0	1.4
HSK-A63/GPS14/90	●	14	31	34	50	90	47.5	37.5	46	TR-4.0	T-3.0	1.4
HSK-A63/GPS16/95	●	16	35	38	50	95	52.5	42.5	51	TR-4.0	T-3.0	1.5
HSK-A63/GPS18/95	●	18	37	40	50	95	52.5	42.5	52	TR-4.0	T-3.0	1.6
HSK-A63/GPS20/100	●	20	39	42	50	100	52.5	42.5	53	TR-4.0	T-3.0	1.7
HSK-A63/GPS25/120	●	25	46	50	-	120	61	51	94	TR-5.0	T-3.0	2.4
HSK-A63/GPS32/125	●	32	56	60	-	125	65	55	99	TR-5.0	T-3.0	3.0

**Availability:** ● Stock ▲ Short lead time ○ On request

- »h6 shank tools must be used.
- »Tool length can be adjusted up to 10mm.
- »T-wrench is must be ordered separately.  
(GRIP torque wrench is recommended.)
- »Data carrier and Coolant tube as an option.
- »All products center through coolant system.
- »Additional sizes and special designs available on request.

⚠ The minimum tool depth must be observed.

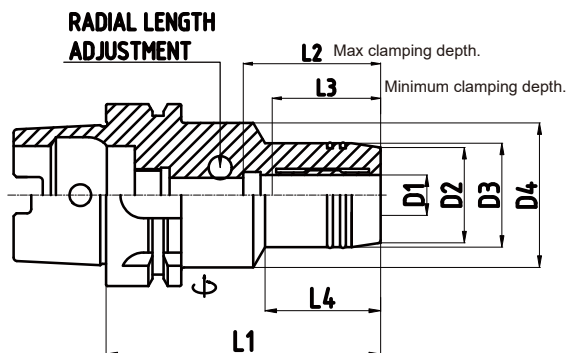

HSK-A63

**Dimensions(mm)**

HSK-A100		D1	D2	D3	D4	L1	L2	L3	L4	Clamping wrench	Radial Adjustment (wrench)	Kg.
HSK-A100/GPS6/85	●	6	23	26	50	85	37.5	27.5	33	TR-4.0	T-2.0	2.8
HSK-A100/GPS8/85	●	8	25	28	50	85	37.5	27.5	33	TR-4.0	T-2.0	2.8
HSK-A100/GPS10/90	●	10	27	30	50	90	42.5	32.5	36	TR-4.0	T-2.0	2.8
HSK-A100/GPS12/95	●	12	29	32	50	95	47.5	37.5	40	TR-4.0	T-2.0	2.8
HSK-A100/GPS14/95	●	14	31	34	50	95	47.5	37.5	46	TR-4.0	T-3.0	2.9
HSK-A100/GPS16/100	●	16	35	38	50	100	52.5	42.5	51	TR-4.0	T-3.0	2.9
HSK-A100/GPS18/100	●	18	37	40	50	100	52.5	42.5	52	TR-4.0	T-3.0	3.0
HSK-A100/GPS20/105	●	20	39	42	50	105	52.5	42.5	58	TR-5.0	T-3.0	3.0
HSK-A100/GPS25/115	●	25	53	57	63	115	61	51	60	TR-5.0	T-3.0	3.7
HSK-A100/GPS32/120	●	32	58	63	75	120	65	55	68	TR-5.0	T-3.0	4.1

PRESET

**Availability:** ● Stock ▲ Short lead time ○ Made to order

- »h6 shank tools must be used.
- »Tool length can be adjusted up to 10mm.
- »T-wrench is must be ordered separately.  
(GRIP torque wrench is recommended.)
- »Data carrier and Coolant tube as an option.
- »All products center through coolant system.
- »Additional sizes and special designs available on request.

⚠ The minimum tool depth must be observed.

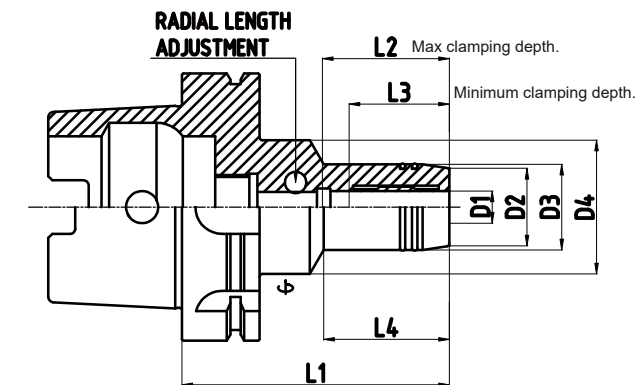

HSK-A100